

FIRE DETECTION DEVICES LTD.

Heat Detector – Double Circuit – N/O Contacts- Sealed

- Combination Rate-of-Rise & Fixed Temperature
Ask for CR 135-2 MP, CR 165-2 MP, CR 200-2 MP
- Fixed Temperature Only
Ask for CF 135-2 MP, CF 165-2 MP, CF 200-2 MP, CF 285-2 MP

Description:

- This is the standard THERMOFLEX™ double circuit, Normally Open (N/O) contacts detector, in which the connectivity is modified with pigtail leads that extend through a seal plate. This provides for enhanced protection against corrosive or moisture-laden environments.
- **Combination Rate-of-Rise & Fixed Temperature**
The Model Number prefix “CR” indicates that the detector is a combination Rate-of-Rise and Fixed Temperature, (often referred to as “Dual-action”), unit. The Rate-of-Rise function allows the detector *to close both sets* of its contacts when the temperature at the ceiling increases at a rate of 8.4 Celsius degrees (15 Fahrenheit degrees) per minute. In most cases, the closure of one set of contacts initiates the Fire Alarm sequence. The second set of contacts is commonly used to initiate an ancillary function. The Fixed Temperature portion consists of a spring-loaded plunger held in place by a eutectic solder that will fuse at the specific temperature (in Fahrenheit degrees) as indicated by the Model Number i.e. 135,165,200 and 285 degrees.
- **Fixed Temperature Only**
The Model Number prefix “CF” indicates that the detector is Fixed Temperature Only, and will therefore *not* respond to a rate of temperature increase but will operate when the detector fuses at the prescribed (Fahrenheit) temperature as indicated by the model number, i.e. 135,165,200 and 285 degrees. This detector is referred to as “Fixed Temperature Only, non-restorable”.
- **Contact Configuration**
The model number suffix “-2”, indicates that the detector is a double circuit with two (2) sets of Normally Open (N/O) contacts. Each set of contacts is provided with 4 fly leads (pigtails). For each set, a pair of black leads connects to one side of the contacts and a pair of white leads connects to the other side of the contacts.
- **Application**
This detector is suitable for use in areas where condensation or corrosion could have harmful effects on circuit wiring connected to standard terminals. Its seal plate (with extended pigtail leads) will mount onto a typical cast exterior back box or standard 4-inch octagon box. The detector is connected to a fire alarm system’s input circuit as an initiating device. The internal contacts are normally open, and will close when the detector operates either on a rate of temperature increase, or if the releasing temperature is reached. It can be installed with an addressing module if it is to be annunciated as a specific room or space, e.g. electrical room, garbage compactor, etc. With its non-metallic diaphragm, the detector can operate normally at low temperatures, making it suitable for non-heated or chilled environments including garages and carports.
The second set of N/O contacts are used to activate a local ancillary function that includes elevator recall, release of magnetically-held doors, local signal operation, local annunciation, etc. In many cases this set of contacts will be connected to a controlling relay that is used to switch heavier voltages.

Engineering Specification:

- Models CR 135-2 MP, CR 165-2 MP and CR 200-2 MP detectors are *dual-action* type, that will respond to a rate of temperature increase at the ceiling of 15 Fahrenheit degrees per minute (8.4 Celsius degrees per minute). These detectors will also respond when the fixed temperature (non-restorable) threshold is exceeded. Dual-action detectors are installed in areas where rapid fluctuations in ceiling temperature are *not* expected.
- In areas where sudden increases in ceiling temperature are normal, specify *Fixed Temperature Only* units i.e. CF 135-2 MP, CF 165-2 MP, CF 200-2 MP or CF 285-2 MP.
- Detectors shall be installed in areas where environmental conditions including dust, vapours, insects, low temperatures, etc., would cause an ionization or photoelectric type detector to initiate a false alarm.
- Detector shall have a proven operating temperature range of; -20°F/+250°F (-30°C/-120°C) exclusive of releasing temperature.
- The fusible link mechanism, when operated, shall be held firmly in place such that the contacts are prohibited from changing state, i.e. reverting back to the normal position.

Temperature and Spacing Chart

	Function Type	Release Temp.	Temp. Rating	Max. Installation Temp	Color dot on fin	Inter-detector Spacing*
CR 135-2 MP	Dual-action	135°F / 57°C	Ordinary	100°F / 37.8°C	None	70ft / 21m
CR 165-2 MP	Dual-action	165°F / 71°C	Ordinary	100°F / 37.8°C	Grey	70ft / 21m
CR 200-2 MP	Dual-action	200°F / 93°C	Intermediate	150°F / 65.6°C	White	70ft / 21m
CF 135-2 MP	Fixed Temp. Only	135°F / 57°C	Ordinary	100°F / 37.8°C	Black	40ft / 12m
CF 165-2 MP	Fixed Temp. Only	165°F / 71°C	Ordinary	100°F / 37.8°C	Black and Grey	25ft / 7.5m
CF 200-2 MP	Fixed Temp, Only	200°F / 93°C	Intermediate	150°F / 65.6°C	Black and White	25ft / 7.5m
CF 285-2 MP	Fixed Temp. Only	285°F / 140°C	High	225°F / 107.2°C	Black and Blue	25ft / 7.5m

* assumes a flat, uninterrupted ceiling at a height not exceeding 10ft / 3m.

Installation:

On conventional, initiating circuits or when using an addressing module, one set of N/O contacts is installed across the circuit such that operation of the detector will create a short circuit condition, required in order to activate the fire alarm control panel (FACP), or addressing module. The second set of N/O contacts are available for ancillary use.

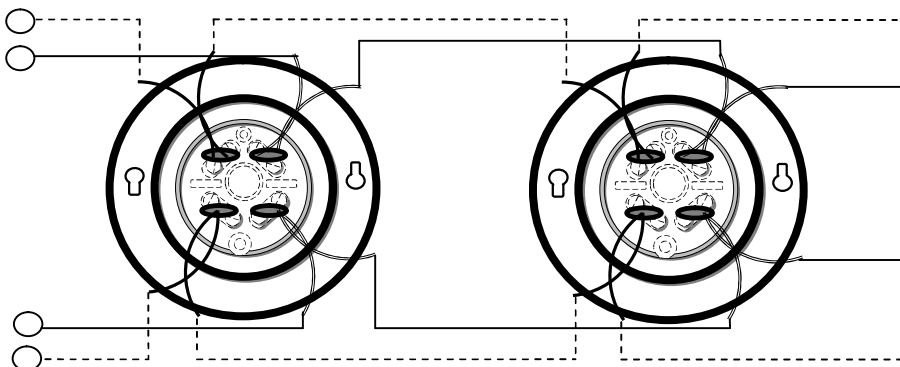

Detector mounts on a standard 4-inch octagon box or 4-inch exterior cast metal back box and gasket as shown here.

Contact Electrical Rating:

3A @ 125 VAC, 1A @ 28 VDC, 0.3A @ 125 VDC, 0.1 A @ 250 VDC

Testing:

- **Testing the “CR” series detector**

Testing the Rate-of-Rise portion, is accomplished by applying heat from a controlled heat source, such as a hair blow dryer, held 8-12 inches away and aimed at the detector. The detector will respond within 6-10 seconds. Providing that the fusible link has not released, the detector will restore as it cools.

NOTE: A heat gun or butane-type device should not be used as the heat output can easily fuse the detector.

- Portable test units designed specifically for this purpose are acceptable, and must bear a UL listing mark.
- Care must be taken to not allow the heat source to reach the device’s fusing temperature. If the detector’s fusing temperature is reached and the plunger is released, the detector will be in permanent alarm and must be replaced.
- Devices using open flame are prohibited from testing heat detectors.

- **Testing the “CF” series detector**

The Fixed Temperature Only detector, **cannot be tested by warming the unit** as permanent contact closure may result, requiring replacement of the detector. Shorting across the pair of pig tail leads connected to the fire alarm input circuit will prove the circuit function and Zone identification.

Fire Detection Devices Ltd. heat detectors for fire alarm systems comply with UL 521 *Heat Detectors for Fire Protective Signaling Systems*, and ULC S531 *Standard for Heat Actuated Fire Detectors for Fire Alarm Systems*. The UL/ULC control number is 41H9, file number S2406. CSFM listing # 7270-1110:0100. Detectors featuring wire (pigtail) leads are included in these documents.